

| | | | |
|---|-----------------|---|---------------------------|
| Document Title: Track motor relief valve, replacing | Function Group: | Information Type: Service Information | Date: 2014/6/12 |
| Profile: EXC, EC210B LC [GB] | | | |

Track motor relief valve, replacing

Op nbr 441-112

1. Park the machine in the service position F, see [091 Service positions](#).
2. When the engine is running, the hydraulic line is under high pressure. Stop the engine, and remove the residual pressure inside the hydraulic line by the travel control lever smoothly for 3 ~ 4 times with ignition switch at "ON" position.

NOTE!

Remove the residual pressure inside the hydraulic tank by pressing the air breather on the hydraulic tank.

3. Remove screws (1) and motor cover (2).

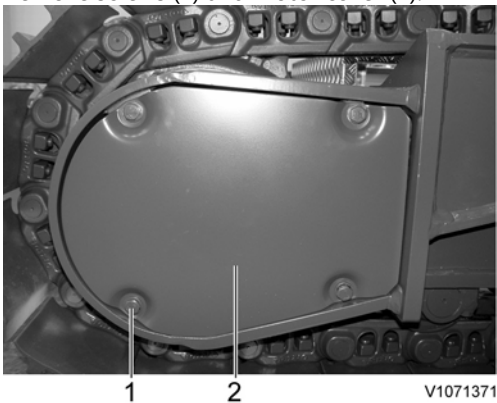

Figure 1
Removal, motor cover

4. Remove track motor relief valve (1).

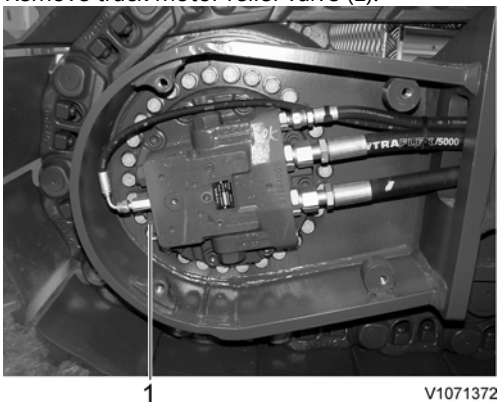

Figure 2
Removal, relief valve

5. Install a new relief valve.
6. Check relief valve pressure of the track motor, and adjust if necessary

| | | | |
|--|-----------------|---|---------------------------|
| Document Title: Track motor, disassembly | Function Group: | Information Type: Service Information | Date: 2014/6/12 |
| Profile: EXC, EC210B LC [GB] | | | |

Track motor, disassembly

Op nbr

Precautions

- Thoroughly clean the gearbox assembly prior to disassembly.
- Select a clean work area.
- Match mark attached components to indicate proper positioning during reassembly.
- Take care not to mix parts of sub assemblies.
- Thoroughly clean all parts and the inside of the casings.
- Inspect and analyze all failures.

Brake valve and motor section

1. Prior to disassembly, install the motor on a rotary work stand. Drain the hydraulic oil & gear oil.

NOTE!

Oil pan size : 4 liter, 8 liter

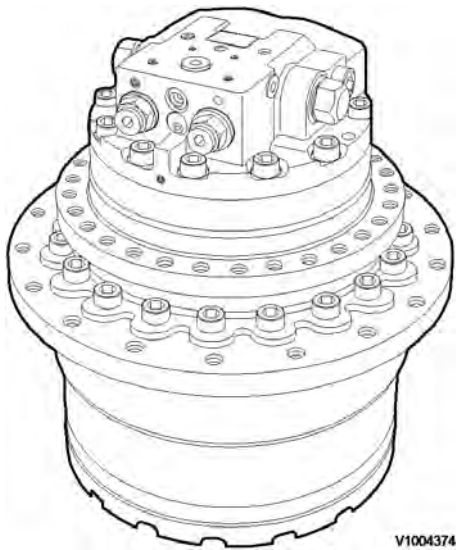

Figure 1
Track motor

2. Remove the relief valve from rear flange (201).
Remove O-ring (108), (109), (110) and back-up rings (111), (117) from relief valve.

NOTE!

Do not reuse O-rings after removal.

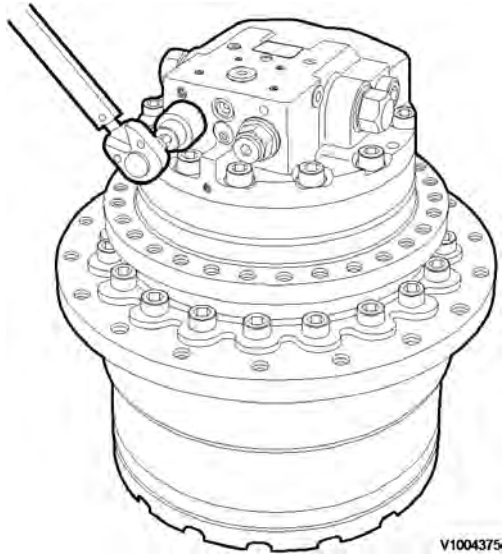

Figure 2
Relief valve, removal

3. Remove screws (243).

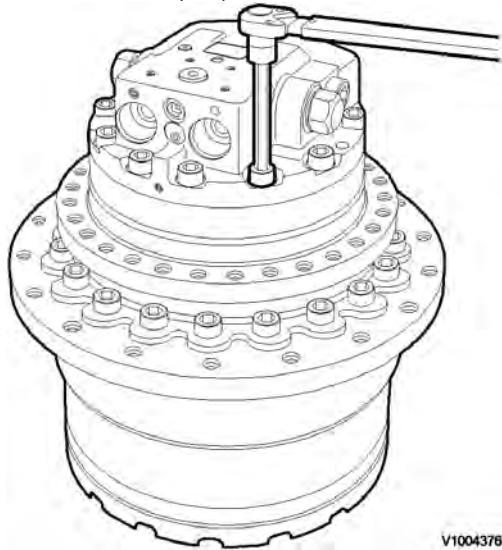

Figure 3
Screws, removal

4. Remove rear flange (201) from spindle (302).

NOTE!

Take care not to remove shaft (2).

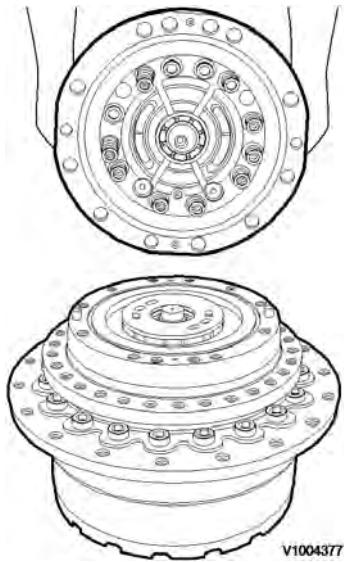

Figure 4
Rear flange, removal

5. Gearbox/hydraulic motor shaft and oil seal.

- Remove valve plate (9), parallel pin (241), brake springs (13) and bearing (50) from rear flange (201) and hydraulic motor.
- Remove O-rings (329) from spindle (302).

NOTE!

Do not reuse O-rings (329) after removal.

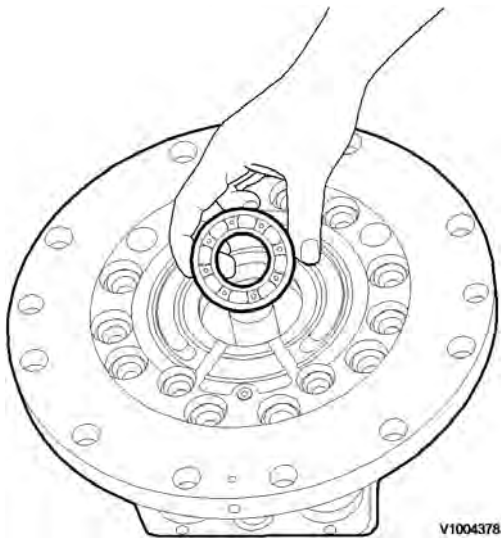

Figure 5
Bearing, removal

Brake valve

6. Counterbalance spool removal.

- Remove plugs (224) from rear flange (201).
- Remove O-ring (236) from plug (224).

NOTE!

Do not reuse O-ring (236) after removal.

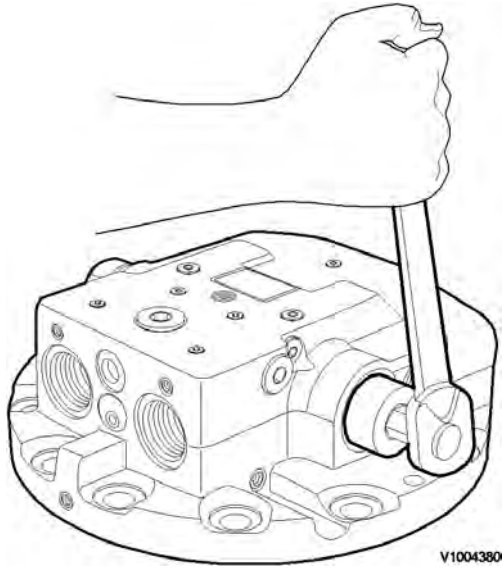

Figure 6
Counterbalance spool, removal

- Remove springs (228), the stoppers (225), and counterbalance spool (223) from rear flange (201).

NOTE!

Be careful not to damage the outer surface of counterbalance spool (223) and the sliding surface of rear flange (201). Since rear flange (201) and counterbalance spool (223) are of the selective-fitting type, replace them together as a kit even if only one of the two parts is damaged.

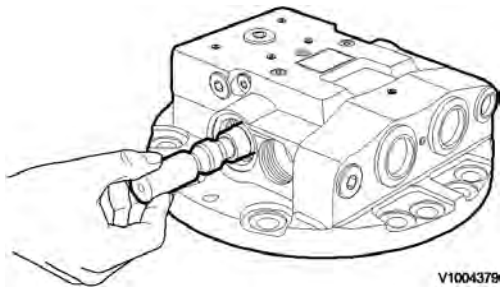

Figure 7
Plug, removal

7. Check valve removal.

- Remove plugs (226) from rear flange (201).



Figure 8
Plug, removal

- Remove springs (230) and check valves (227) from rear flange (201).

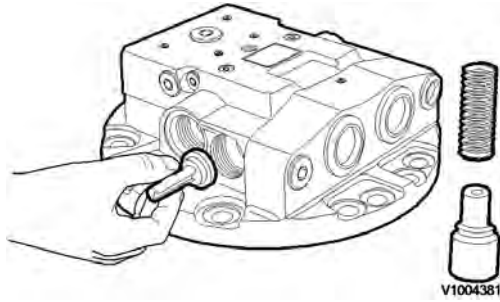

Figure 9
Check valve, removal
NOTE!

Be careful not to damage the seat sections of check valve (227) or rear flange (201).

- Remove O-ring (237) from plug (226).

NOTE!

Do not reuse O-ring (237) after removal.

8. Two-speed valve removal.

- Remove plugs (257) from rear flange (201).



Figure 11
Spool, removal

- Remove spool (263) and spring (266) from rear flange (201).
- Remove O-rings (295) from plugs (257).

NOTE!

Do not reuse O-ring (295) after removal.

9. Removal of internal parts.

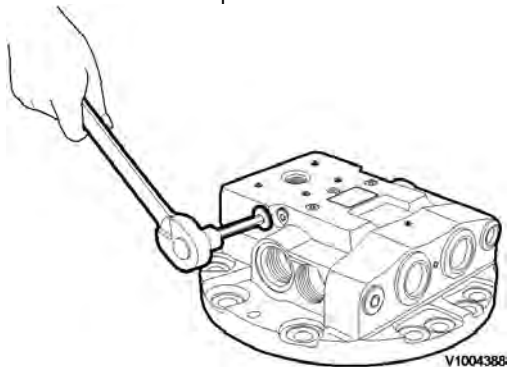

Figure 12

Plug, removal

- Remove plug (280) from flange (201).

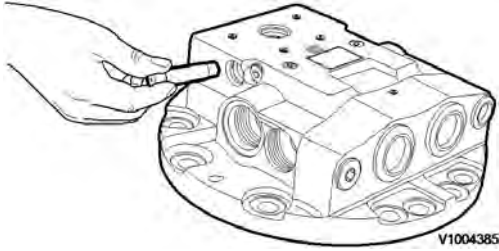

Figure 13

Piston, removal

- Remove O-ring (296) from plug (280).
- Remove piston (281) from rear flange (201).

NOTE!

Take care not to damage the piston hole.

NOTE!

Since rear flange (201) and piston (281) are of the selective fitting type, replace them together as a kit.

- Remove plug (282), O-ring (283), (284).

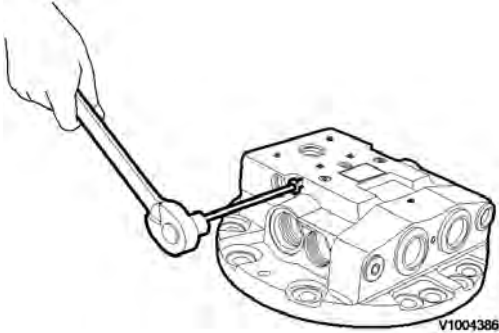

Figure 14

Plug, removal

NOTE!

Do not reuse O-ring after removal.

- Remove steel balls (285) from rear flange (201).

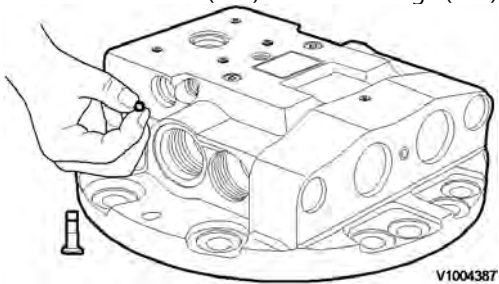

Figure 15

Steel ball, removal

10. Relief valve removal.



Figure 16
Plug, removal

- Remove plug (104) and remove sleeve (102).

NOTE!

Do not interchange the parts of the two relief valves.

- Remove O-ring (110) from plug (104).

NOTE!

Do not reuse O-ring after removal.

- Remove shim (105) from plug (104).
- Take out spring retainer (103), spring (106), and piston (101) in that order from sleeve (102).
- Remove seal (120) from piston (101).
- Disassemble the other side sleeve in the same method.

NOTE!

If the parts, except O-ring (110) and seal (120) need to be replaced the relief valve must be reset on a test bench. Therefore replace the relief valve assembly.



Figure 17
Spring retainer, removal



Figure 18
Spring, removal



Figure 19

Shim, removal



Figure 20
Relief valve piston, removal

Hydraulic motor, disassembly

11. Parking brake removal.



WARNING

Abrupt injection of compressed air may cause piston to pop out. To ensure your safety, apply a protective cover over the piston.

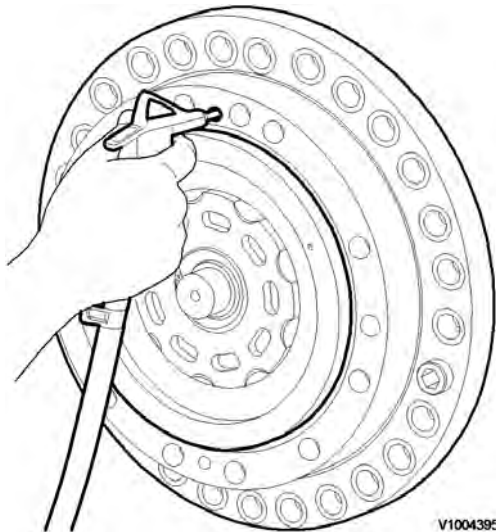

Figure 21
Apply the compressed air

- Remove brake piston (12) by injecting compressed air (pressure : 3~5 kgf/cm²) into the parking brake access hole in spindle (302).

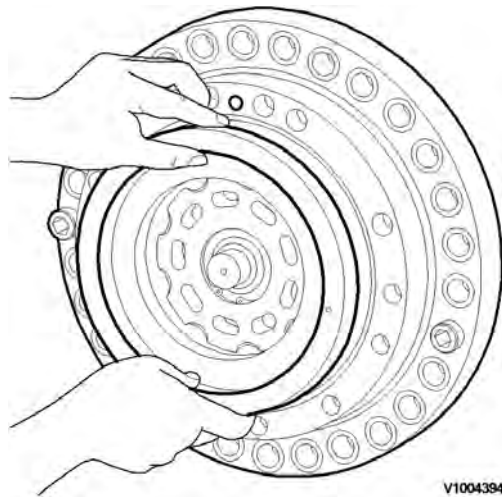

Figure 22
Brake piston, removal

- Remove O-rings (35 and 39) from piston (12).
NOTE!
Do not reuse O-rings (35) (39) after removal.

12. Removal of rotary group.

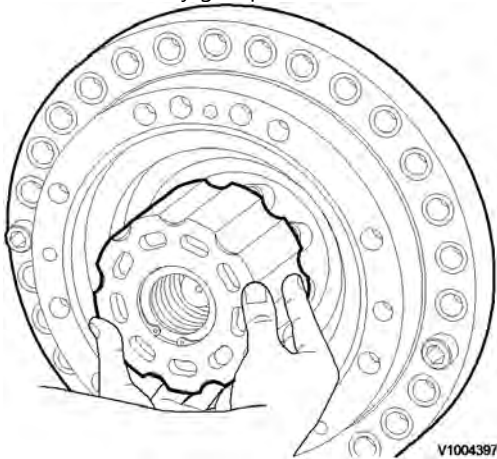

Figure 23
Cylinder block, removal

- Place an oil pan under spindle (302).
NOTE!
Pistons must be installed into the same bores because of wear pattern. Mark the pistons and respective cylinder bores.
NOTE!
Before removal, hold cylinder block (4) with both hands and turn it two to three times in a clockwise and counterclockwise direction alternately, to detach shoes (6) from swash plate (3).
NOTE!
Be careful when removing the cylinder block that the pistons and needle rollers (51) do not fall into the spindle.
- Hold cylinder block (4) with both hands, and remove it from spindle (302).
- Remove swash plate (3), steel balls (67) from spindle (302).
- Remove the mating plates (16) and friction plates (15) that are mounted on the outer surface of cylinder block (4).
- Remove the piston assembly (5), shoe (6), retainer plate (7), thrust ball (8), and needle rollers (51) from cylinder block (4).

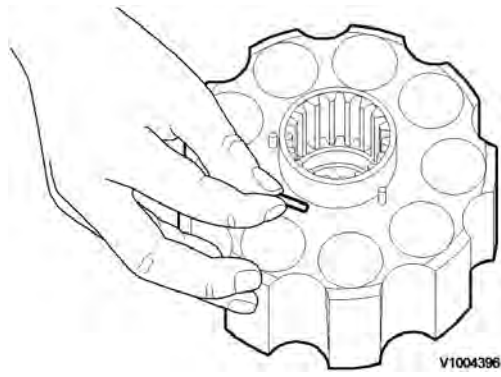

Figure 24
Needle roller, removal

13. Remove the swash plate (3) from spindle (302).

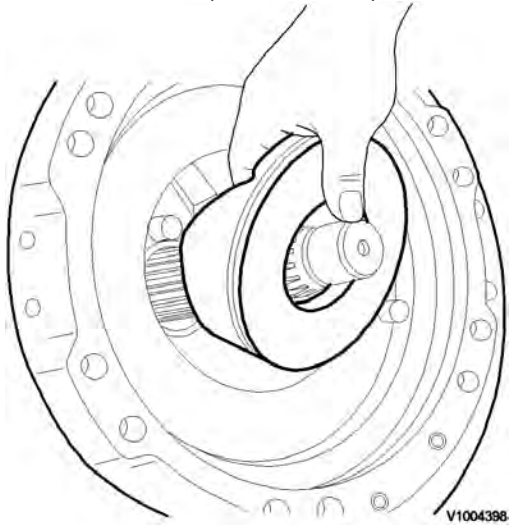

Figure 25
Swash plate, removal

14. Remove the drive shaft (2) from spindle (302) by striking the front part lightly with a plastic hammer.

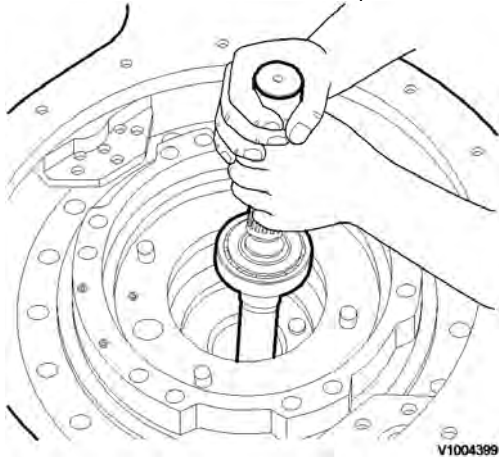

Figure 26
Drive shaft, removal

15. Remove the bearing (49) from drive shaft (2).

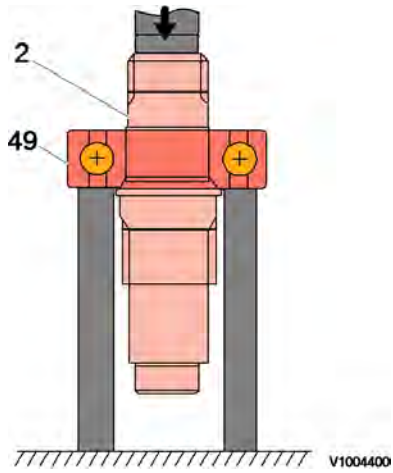

Figure 27
Bearing, removal

16. Remove the steel ball (67) and parallel pin (71) from spindle (302).

⚠ WARNING

Abrupt injection of compressed air may cause piston to pop out. To ensure your safety, apply a protective cover over the piston.

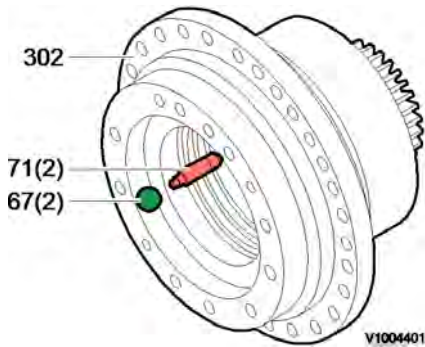

Figure 28
Steel ball and parallel pin, removal

17. Remove the speed selector piston assembly [piston (61) and shoe (62)] from spindle (302) by feeding compressed air (pressure : 3 ~ 5 kgf/cm²) into the access hole in spindle (302).



Figure 29
Piston, removal

NOTE!

The rotary group parts must be replaced as a set. Reference the parts catalog for details.

18. Remove the seal (32) from spindle (302).

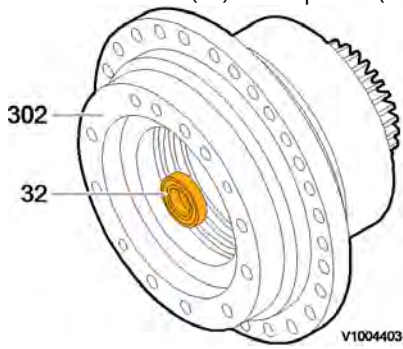

Figure 30
Bearing and seal, removal

19. Cylinder block disassembly

- Place cylinder block (4) on a press bench, then while pressing holding retainer (I) against washer (10), remove snap ring (45).

NOTE!

Press load : 200 kg or over.

NOTE!

When removing the spring, press the axial centers of retainer (I) and washer to prevent the cylinder block from being damaged by contact.

NOTE!

Protect the sliding surface of the cylinder block with a rubber sheet.

NOTE!

Remove spring (14) only if it is to be replaced.

! WARNING

Do not release the press abruptly. The spring could pop out and cause an injury.

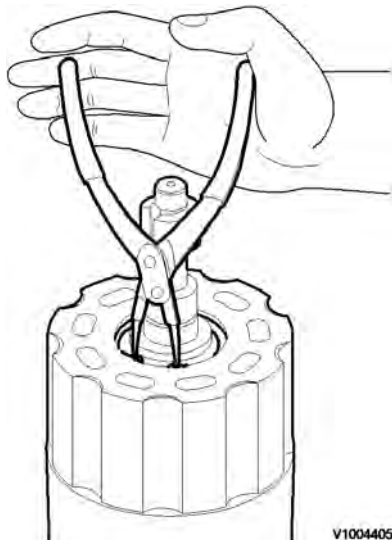
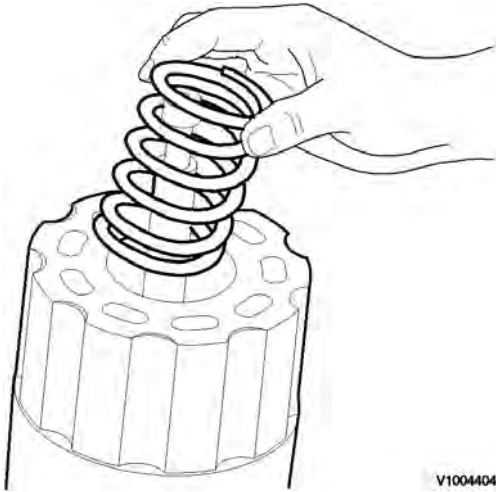

Figure 31
Snap ring, removal

- Slowly release the press until the spring force is relaxed.
- Remove washer (10), spring (14), and washer (10), in that order, from cylinder block (4).



V1004404

Figure 32
Spring, removal

| | | | |
|---|-----------------|---|---------------------------|
| Document Title: Track motor, assembly | Function Group: | Information Type: Service Information | Date: 2014/6/12 |
| Profile: EXC, EC210B LC [GB] | | | |

Track motor, assembly

Op nbr

Precautions

- Clean all parts with cleaning solvent and dry with compressed air.
- Rework damaged parts and before assembling, prepare all replacement parts.
- Coat the sliding parts, bearings and gears with clean gear oil.
- Coat the motor assembly sliding parts and bearings with clean hydraulic oil.
- Replace the O-rings, and seals.
- Use a torque wrench to tighten the screws and plugs to the specified torque.

Tightening torque

| Item No. | Description | Thread size | Torque, kgf·m (lbf·ft) |
|----------|-------------|-------------|-------------------------|
| 102 | Sleeve | PF 1 | 25 ± 5 (180 ± 36) |
| 104 | Plug | PF 1/2 | 10 ± 2 (72 ± 14) |
| 224 | Plug | M36 (P 1.5) | 45 ± 9 (325 ± 65) |
| 226 | Plug | M36 (P 1.5) | 26 ± 4 (188 ± 29) |
| 243 | Screw | M16 (P 2.0) | 25.7 ± 4 (186 ± 29) |
| 246, 252 | Plug | PT 1/4 | 3 ± 0.5 (22 ± 4) |
| 254 | Plug | NPTF 1/16 | 1.0 ± 0.25 (7.2 ± 1.8) |
| 257 | Plug | PF 1/2 | 10 ± 2 (72 ± 14) |
| 280 | Plug | PF 3/8 | 6 ± 1 (43 ± 7) |
| 282 | Plug | PF 1/8 | 1.5 ± 0.25 (10.8 ± 1.8) |
| 298 | Plug | PF 1/8 | 1.25 ± 0.25 (9 ± 1.8) |

Brake valve, assembly

1. Check valves

- Fit O-ring (237) on plug (226).
- Install spring (230) and check valve (227) to plug (226), then grease the spring and valve assembly.
- Insert plug (226) in conjunction with spring and valve, into rear flange (201), and tighten the plug to the required torque (26 ± 4 kgf·m (186 ± 29 lbf·ft)).

NOTE!

Apply grease to O-ring (237).

NOTE!

Coat the thread section of plug (226) with loctite #577.

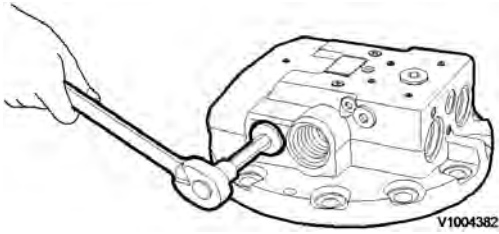

Figure 1
Plug, install

2. Counterbalance spool

- Insert spool (223) into rear flange (201).

NOTE!

Apply hydraulic oil to spool (223) and insert it into rear flange (201).

NOTE!

Damage to the bore section of the rear flange or the surface of the spool may cause internal leakage to occur after reassembling, and motor performance to deteriorate.

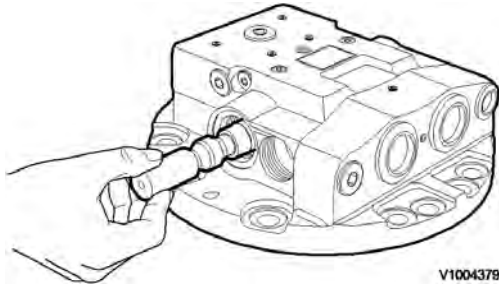

Figure 2
Counterbalance spool, install

- Attach O-ring (236).

NOTE!

Apply grease to the O-ring.

- Install stopper (225) and spring (228) into both plugs (224), and tighten plugs (224) into rear flange (201) to the required torque (45 ± 9 kgf-m (325 ± 65 lbf-ft)).

NOTE!

If either the rear flange (201) or spool (223) is to be replaced, the entire assembly (kit) must be replaced.

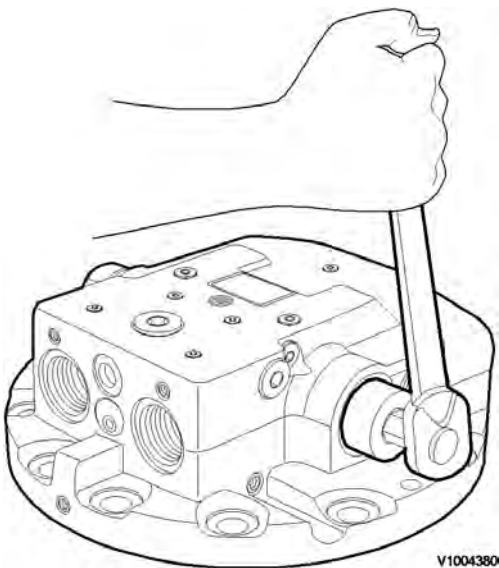

Figure 3
Plug, install

3. Speed selector valve.

- Fit O-rings (295) on plugs (257).
- Install spring (266) onto spool (263) and insert into rear flange (201).

NOTE!

Apply grease to the O-ring.

NOTE!

Apply hydraulic oil to spool (263) and insert it into rear flange (201).

NOTE!

Damage to the bore section of the rear flange or the surface of the spool may cause internal leakage to occur after reassembling, and motor performance to deteriorate.



Figure 4

Spool, install

- Tighten plugs (257) into rear flange (201) to the required torque (10 ± 2 kgf-m (72 ± 14 lbf-ft)).

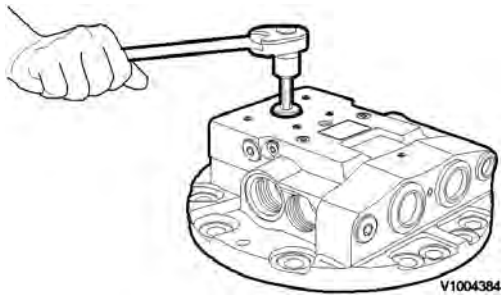

Figure 5

Plug, install

4. Shock relief valve parts.

- Insert steel balls (285) into rear flange (201).
- Mount O-rings (283), (284) on plugs (282).

NOTE!

Apply grease to the O-ring.

Thank you very much for reading.

This is part of the demo page.

GET MORE:

Hydraulic

System, Setting

Instructions, Functional

Description, Electrical

System And more.....

Click Here BUY NOW

Then Instant Download

the Complete Manual.